

Quantos Automated Dosing

Powder Module

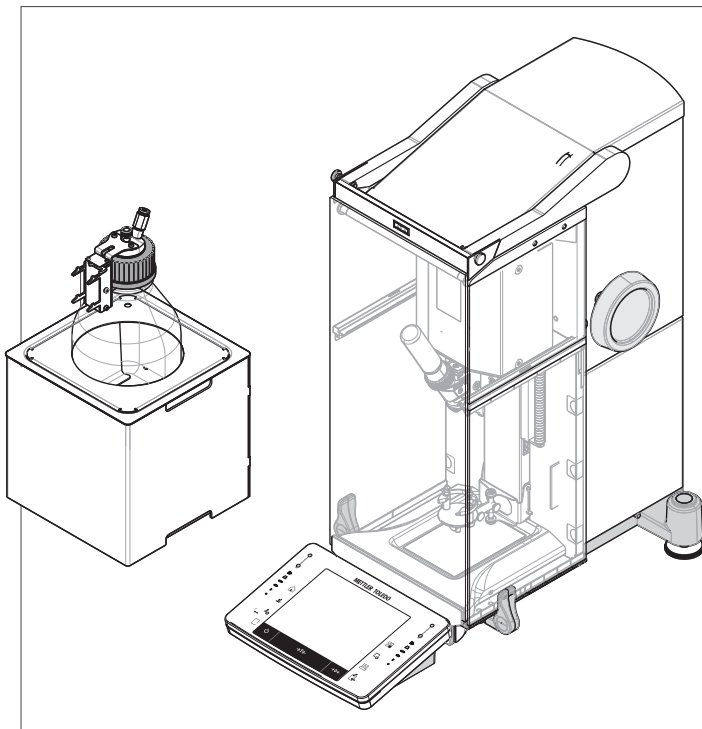

METTLER TOLEDO

Overview dosing unit

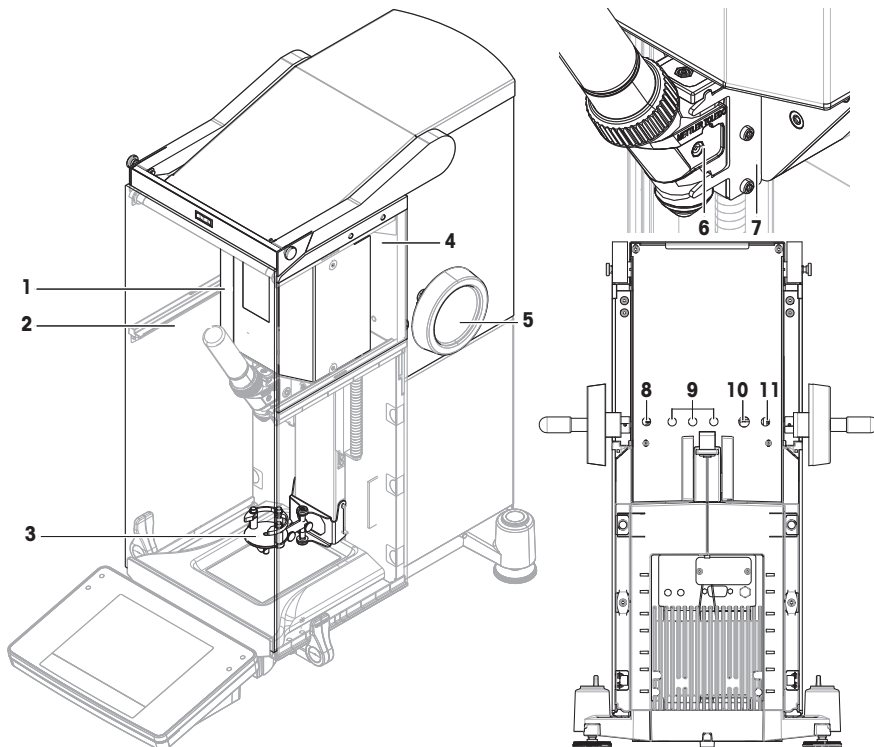

Legend Powder Module

Powder module		Dosing head and backside	
1	Drive unit	6	Dosing head
2	Front door	7	Dosing head support
3	ErgoClip Quantos	8	Power supply cable (from AC adapter)
4	Upper side glass	9	Connector for autosampler and CAN devices
5	Head height adjustment handle	10	RS232C interface - cable to balance
		11	Power supply cable from powder module to balance

1 Safety Information

- Read and understand the instructions in this manual before using the device.
- Keep this manual for future reference.
- Include this manual if you pass on the device to other parties.

If the device is not used according to the instructions in this manual or if it is modified, the safety of the device may be impaired and Mettler-Toledo GmbH assumes no liability.

1.1 Definitions of signal words and warning symbols

Safety notes contain important information on safety issues. Ignoring the safety notes may lead to personal injury, damage to the instrument, malfunctions and false results. Safety notes are marked with the following signal words and warning symbols:

Signal words

- WARNING** A hazardous situation with medium risk, possibly resulting in death or severe injury if not avoided.
- CAUTION** A hazardous situation with low risk, resulting in minor or moderate injury if not avoided.
- NOTICE** A hazardous situation with low risk, resulting in damage to the instrument, other material damage, malfunctions and erroneous results, or loss of data.

Warning symbols



Electrical shock



Toxic substance



Explosion



Inflammable substance



Bruising



General hazard: read the User Manual or the Reference Manual for information about the hazards and the resulting measures.



Notice

1.2 Product-specific safety notes

Intended use

This dosing system is designed to be used in analytical laboratories by trained staff. The dosing system is intended for weighing and dosing powder or liquid samples.

Any other type of use and operation beyond the limits of use stated by Mettler-Toledo GmbH without consent from Mettler-Toledo GmbH is considered as not intended.

Responsibilities of the instrument owner

The instrument owner is the person holding the legal title to the instrument and who uses the instrument or authorizes any person to use it, or the person who is deemed by law to be the operator of the instrument. The instrument owner is responsible for the safety of all users of the instrument and third parties.

METTLER TOLEDO assumes that the instrument owner trains users to safely use the instrument in their workplace and deal with potential hazards. METTLER TOLEDO assumes that the instrument owner provides the necessary protective gear.

Protective equipment



Chemical-resistant gloves



Goggles



Lab coat

Safety notes



⚠ WARNING

Death or serious injury due to electric shock

Contact with parts that carry a live current can lead to death or injury.

- 1 Only use the approved METTLER TOLEDO power supply cable and AC/DC adapter with a current-limited SELV output.
- 2 Connect the power cable to a grounded power outlet, ensure correct polarity.
- 3 Keep all electrical cables and connections away from liquids and moisture.
- 4 Check the cables and power plug for damage and replace damaged cables and power plugs.



⚠ WARNING

Injury and/or damage due to hazardous substances

Chemical, biological or radioactive hazards can be associated with the substances processed by the instrument. During dosing procedures, small amounts of the dosed substance may become airborne and penetrate the instrument or contaminate its surroundings.

The substance characteristics and related hazards is the full responsibility of the instrument owner.

- 1 Be aware of possible hazards associated with the substance and take adequate safety measures, e.g., those stated on the safety data sheet provided by the manufacturer.
- 2 Make sure that every instrument part in contact with the substance will not get altered or damaged by the substance.



⚠ WARNING

Injury or damage due to powder handling

Powders may get compacted in the dosing head and block it. Too much force applied by the dosing head mechanism may lead to a break and potentially hazardous substances may get airborne.

- 1 Handle the dosing heads with care.
- 2 If the dosing head seems blocked, avoid further dosing. Remove the head from the instrument and turn it upside down to loosen the powder.
- 3 Cease work immediately in the event of leak or break.



⚠ WARNING

Injury and/or damage due to reacting, flammable, or explosive substances

During the dosing procedure, substances could be combined and cause an exothermic reaction or explosion. This includes powders, liquids, and gases. It may lead to serious injuries and significant material damage.

The sample characteristics and related hazards is the full responsibility of the instrument owner.

- 1 Be aware of possible hazards associated with reacting, flammable, or explosive substances.
- 2 Ensure a working temperature low enough to prevent the formation of flames or an explosion.



⚠ WARNING

Injury or death due to toxic substances

If you use toxic, explosive, or flammable liquids with the pump module, the exhaust air will be contaminated.

- Connect a tube to the exhaust air outlet to collect the contaminated air.



WARNING

Injury and/or damage due to reacting substances

When pressure is released from the bottle, the air/gas in the bottle moves back towards the pump module. The air/gas coming from the coupled outlets mixes in the pump module. Molecules of the substances in the various bottles can get in contact through this contaminated air/gas.

- 1 Do not connect bottles with incompatible liquids to the same pump module simultaneously.
- 2 Before connecting a second, incompatible liquid to the pump module, disconnect the first bottle and purge the pump with clean air/gas.



WARNING

Injury and damage to pump or bottle due to high pressure

High pressure from external gas can damage the pump or the bottle.

- 1 Use a regulator on the external gas line.
- 2 Ensure that the pressure of the external gas does not exceed 0.2 bar (2.9 psi).



CAUTION

Injury due to splashing liquids

If the pressure in the bottle is not released, liquid might splash when removing the micro dosing valve, opening the bottle, or removing the liquid tube.

- Always release pressure by switching off the instrument before removing the micro dosing valve, opening the bottle, or removing the liquid tube.



CAUTION

Injury due to moving parts

- Do not reach into the working area while parts of the instrument are moving.



CAUTION

Injury due to sharp objects or broken glass

Instrument components, e.g., glass, can break and lead to injuries.

- Always proceed with focus and care.



NOTICE

Damage to the instrument due to the use of unsuitable parts

Using unsuitable parts with the instrument can damage the instrument or cause it to malfunction.

- Only use parts from METTLER TOLEDO that are intended to be used with your instrument.



NOTICE

Damage to the device

The device contains no user-serviceable parts.

- 1 Do not open the device.
- 2 In the event of problems, please contact a METTLER TOLEDO representative.



NOTICE

Damage to the instrument due to inappropriate cleaning methods

The instrument can be damaged by certain cleaning agents, solvents, or abrasives. If liquids enter the housing, they can damage the instrument.

- 1 Only use a wet cloth with water and a mild detergent to clean the instrument or terminal.
- 2 Wipe off any spills immediately.
- 3 Make sure that no liquid penetrates the instrument.

2 Design and Function

2.1 Dosing heads and equipment

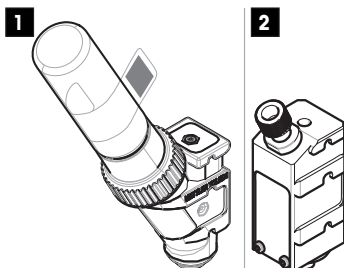

1	Powder dosing head (e.g. QH008-BNMW) This is the standard dosing head for powder dosing. It is used together with a vial.
2	Liquid dosing head (e.g. QL001) This is the standard dosing head for liquid dosing. It is used together with a pump module and bottle.

Powder dosing head

The spare cap included in the delivery may be used to close the dosing head without a vial. Vials and storage containers need to be purchased separately.

You can print a label with the dosing-head data from the RFID tag and affix this label to the dosing head.

Powder test head

This dosing head is provided with a vial filled with calcium carbonate (CaCO_3). The powder test head is equipped with a test function that dispenses 10 times a defined mass and reports the **Repeatability** and **Dosing time** results. If your instrument failed the tests, inform a METTLER TOLEDO service technician.

MinWeigh dosing head

The MinWeigh dosing head performs a minimum weight test automatically by placing a test weight on given tare weights. The procedure will be repeated 10 times to define the automated minimum weight.

2.2 Data stored in the dosing head's RFID tag

Every dosing head is equipped with an integrated RFID tag (1) which stores and exchanges data with the instrument.

The following data is stored in the RFID tag of the head:

- **User data**
- This block holds information about the substance such as the name of the substance, the filling and expiry dates, the quantity, etc. This data can be edited by the user at any time and should be entered before using a new head for the first time to have the data available for reports and labels.

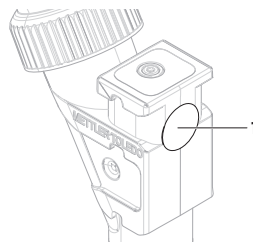

Note for powder dosing heads

The counter for the remaining powder dosing cycles is based on the lifetime limit of the dosing head (max. 999). With every dosing cycle started, the counter is decreased by 1. If the counter drops to zero, the dosing head must be replaced. If the vial of the old head still contains a considerable amount of powder, you may remove the vial from the old dosing head and screw it onto the new dosing head. Copy the user data and the powder content value from the old dosing head to the new dosing head.

If the remaining quantity of powder is insufficient for the next dosing cycle, a warning message will appear.

3 Installation and Putting into Operation



This User Manual is a brief instruction that provides information to handle with the first steps of the instrument in a safe and efficient manner. Personnel must have carefully read and understood this manual before performing any tasks.

For full information, always consult the Reference Manual (RM).

► www.mt.com/Powder-Module-RM

The instrument is installed by METTLER TOLEDO service technicians. This includes the wiring as well as the configuration of the interfaces and peripherals.

3.1 Scope of delivery



NOTICE

Damage to the instrument due to the use of unsuitable parts

Using unsuitable parts with the instrument can damage the instrument or cause it to malfunction.

- Only use parts from METTLER TOLEDO that are intended to be used with your instrument.

Q2 Powder module

- Powder module
- Conductive front door
- Set of upper side glasses for powder module
- Set of bolts for upper side glasses
- ErgoClip Quantos
- Front cover
- Type label (standard or approved balance), to be affixed to the powder module
- Dosing head starter kit
- User Manual

QLL standard kit for bottles (optional)

- Liquid head QL001
- Pressure-resistant bottle
- Bottle cap (GL45) with fitting and support
- Micro dosing valve tool
- Spare part set (incl. filter, sealing ring, fastening nut)
- Liquid tube
- Air tube

QL2 pump module (optional)

- Pump module
- Liquid side doors for Q2
- Muffler
- Bottle holder
- Drip pan
- CAN-cable

Recommended options

- Ethernet Option
- Ethernet / RS232 (Netcom kit)
- AntiStatic kit
- Cable box

3.2 Selecting the location

An optimal location will ensure accurate and reliable operation of the instrument. The surface must be able to safely take the weight of the instrument when fully loaded. The following local conditions must be observed:

- The instrument must only be used indoors and up to a maximum altitude of 4000 m above sea level.
- Before switching on the balance, wait until all parts are at room temperature (+5 to 40 °C).
The humidity must be between 10% and 80% non-condensing.
- The power plug must be accessible at all times.
- Firm, horizontal and vibration-free location.
- Avoid direct sunlight.
- No excessive temperature fluctuations.
- No strong drafts.

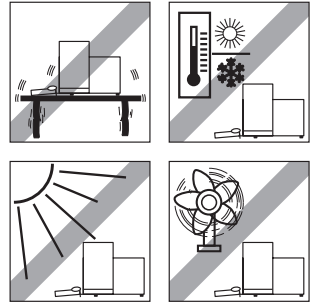

If the instrument is not horizontal at the outset, it must be leveled during commissioning.

3.3 Assembling powder module



The instrument is mounted and installed by a METTLER TOLEDO service technician.

3.4 Installing and removing dosing head

Installing dosing head



Refer to your XPE Operating Instructions for further information on the function of the keys.

- 1 To open the front door, press key .
- 2 To open the side doors, press key .

Note

If you have an autosampler installed, these keys may have a different function.

- 3 Slide dosing head onto the dosing head support until it comes to a stop.
- 4 Press it down slightly until it is properly seated in the holding pins (1).

Note

The dosing head will be locked automatically, as soon as first dosing starts.

⇒ The dosing head is ready to dose.

Removing dosing head

Once the dosing head has been locked, you have to unlock the head before removing it.

- Function key **Un/Lock** must be active.
- 1 Tap **Un/Lock**.
⇒ The dosing head is being unlocked.
 - 2 Remove dosing head by pulling it outwards carefully.

► www.mt.com/library

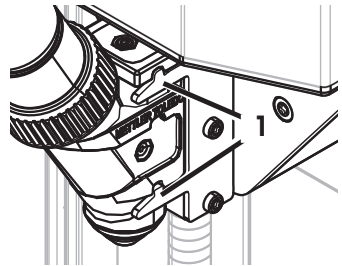

3.5 Assembling pump module and bottle



⚠ WARNING

Injury and damage to pump or bottle due to high pressure

High pressure from external gas can damage the pump or the bottle.

- 1 Use a regulator on the external gas line.
- 2 Ensure that the pressure of the external gas does not exceed 0.2 bar (2.9 psi).

- Assemble pump module and bottle according to figure.

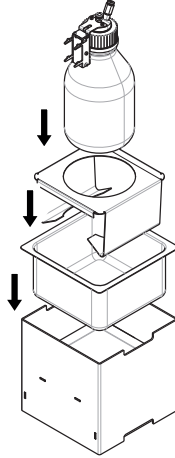

Inserting and removing a liquid dosing head in and from the liquid dosing head support



⚠ CAUTION

Injury due to splashing liquids

If the pressure in the bottle is not released, liquid might splash when removing the micro dosing valve, opening the bottle, or removing the liquid tube.

- Always release pressure by switching off the instrument before removing the micro dosing valve, opening the bottle, or removing the liquid tube.

- 1 Insert liquid dosing head in the liquid dosing head support.

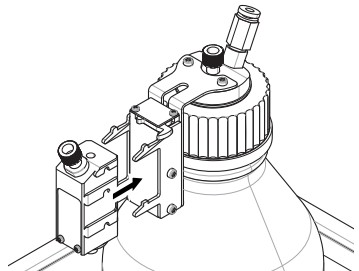

- To remove liquid dosing head from the liquid dosing head support, pull the catch (1) to the front and remove liquid dosing head (2).

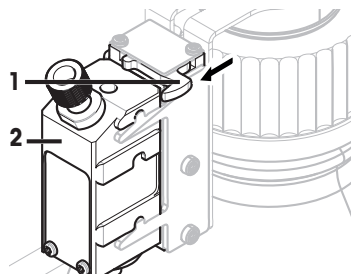

3.6 Connecting the tubes

Connectors of pump module

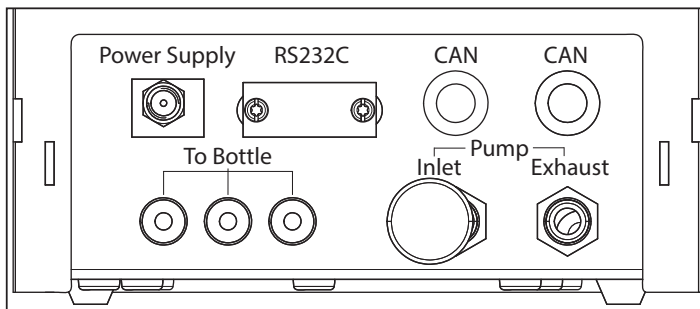

Tubes definition

The thinner tube is used for transporting liquid from the bottle to the liquid dosing head. The slightly bigger tube is used for pumping air into the bottle. By adding air, pressure rises in the bottle. When pressure reaches min. 0.3 to max 0.5 bar (4.4 to 7.2 psi) the micro dispensing valve in the dosing head opens and liquid can ascend the liquid tube. The two tubes are further referred to as liquid tube and air tube.

Connecting the liquid tube

- The liquid dosing head is inserted in the liquid dosing head support.

- Place the sealing ring (1) on the table with the wider end on the table.
- Take the end of the liquid tube and press it into the sealing ring.
 - ⇒ This is the dosing-head end of the tube. The opposite end is the bottle end.
- Thread the fastening nuts (2), paying attention to the orientation.
- Thread the sealing ring (3) from the bottle end of the tube (slide until 220 mm from the end using the micro dosing valve tool). Pay attention to the orientation.

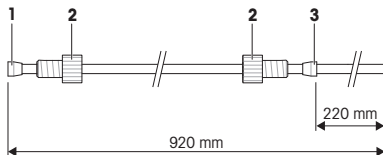

- 5 Insert the dosing-head end of the tube (4) in the dosing head (5).
- 6 Tightly fasten the fastening nut to the dosing head.
- 7 Insert the bottle end of the tube through the corresponding hole in the bottle cap (6). The tube should reach the bottom of the bottle.
- 8 Attach the suction filter to the bottle end of the tube.
- 9 Screw the cap to the bottle.

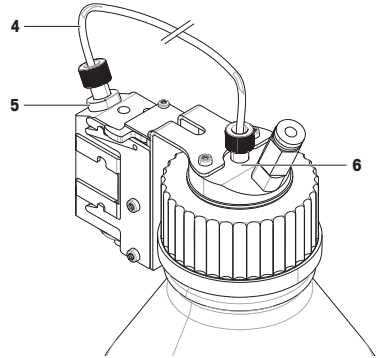

Connecting the air tube



⚠ WARNING

Injury and/or damage due to reacting substances

When pressure is released from the bottle, the air/gas in the bottle moves back towards the pump module. The air/gas coming from the coupled outlets mixes in the pump module. Molecules of the substances in the various bottles can get in contact through this contaminated air/gas.

- 1 Do not connect bottles with incompatible liquids to the same pump module simultaneously.
- 2 Before connecting a second, incompatible liquid to the pump module, disconnect the first bottle and purge the pump with clean air/gas.



NOTICE

Damage to tube connectors due to mishandling

If the tubes are not removed correctly, the connectors and therefore the pump module can be damaged.

Wrongly cut tubing can result in leaking connections.

- 1 To remove the tubes, press down the ring on the connector and pull out the tube carefully.
- 2 Cut the tubes with a tube cutter.

- 1 Connect the air tube (8) to the air inlet of the bottle (7)
- 2 Connect the other end of the air tube to the air outlet of the pump module (9).
- 3 Insert the muffler into the air inlet of the pump module (10) to absorb the noise.

When a tube is connected to the air outlet of the pump, the valve of the air outlet opens. Never leave a tube that is connected to the air outlet unconnected at the other end because pressure can not be built up. You can connect up to 3 bottles to the pump module.

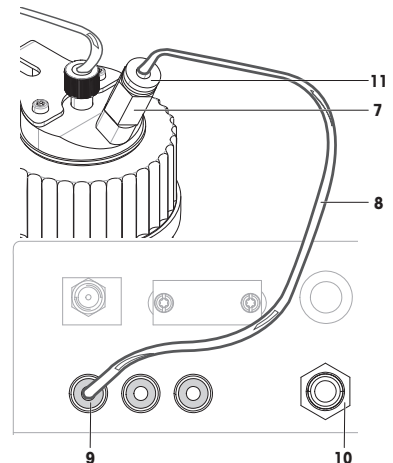

Removing the air tube

- 1 Remove the air tube (8) from the bottle by firmly pressing down the ring (11) at the air inlet (7).
- 2 If necessary, remove the air tube from the pump module by pushing the ring (9).

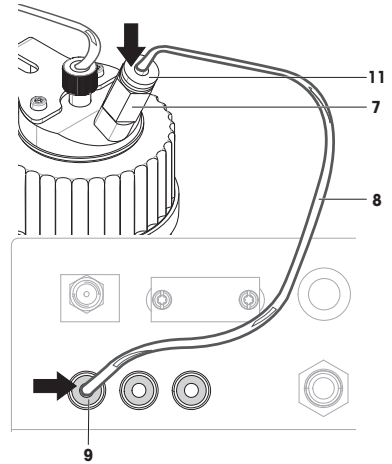

Using the pump with external gas



WARNING

Injury and damage to pump or bottle due to high pressure

High pressure from external gas can damage the pump or the bottle.

- 1 Use a regulator on the external gas line.
- 2 Ensure that the pressure of the external gas does not exceed 0.2 bar (2.9 psi).

- 1 The liquid can be protected by feeding an external gas, e.g., nitrogen, to the pump. Make sure that the pressure of the external gas does not exceed 0.2 bar (2.9 psi).
- 2 Remove the muffler from the air inlet of the pump module (10).
- 3 Connect the tube to the air inlet of the pump module (10).

Note

Outer tube diameter: 6 mm

Pressure range: 0.1 to 0.2 bar (1.5 to 2.9 psi)

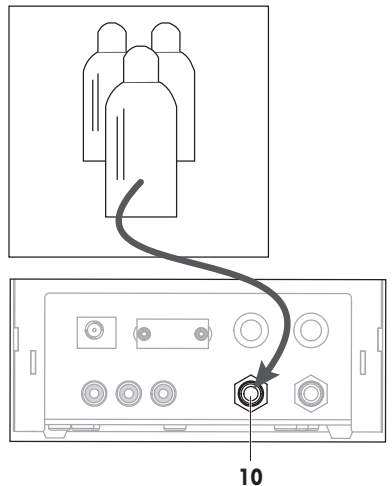

Contaminated air by using toxic, explosive or flammable liquids



⚠ WARNING

Injury or death due to toxic substances

If you use toxic, explosive, or flammable liquids with the pump module, the exhaust air will be contaminated.

- Connect a tube to the exhaust air outlet to collect the contaminated air.

- Connect a tube to exhaust air outlet (12) to collect the contaminated air into a safe container.

📖 Note

Outer tube diameter: 6 mm

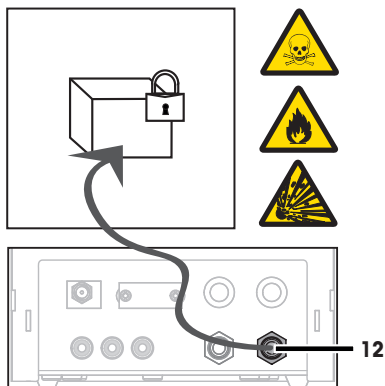

4 Operation

4.1 Powder dosing

4.1.1 Basic operation settings



Refer to your XPE Operating Instructions for further information on settings and parameters.

► www.mt.com/library

Navigation: ☰ > Powder module > Mounted

If you dose powder for the first time, or after a master reset, check following settings:

- Dosing must be chosen as application: ☰ > **Dosing**
- Powder module must be defined as mounted: ☰ > **Powder module > Mounted**
- RS232 device must be activated: ☰ > **System > Peripherals > RFID / Quantos > RS232 built-in**
- If front door is used, front door must be defined as mounted: ☰ > **Powder module > Mounted > Front door > Mounted**
- If liquid module is mounted, liquid module must be defined as mounted: ☰ > **Liquid module > Mounted**

4.1.2 Working with powder module

If you tap **Start** with the liquid module, you get these options:



Solution	To prepare a solution with defined concentration solid/liquid in mg/g .	See [Prepare a solution ► Page 16]
Solid dosing	To dose a powder.	See [Dosing powder ► Page 15]
Liquid dosing	To dose a liquid.	See [Dosing liquid ► Page 16]
Cancel	To return.	

4.1.3 Dosing powder

Navigation:  > **Dosing steps** > **Dosing steps (solid)**...

The following procedure is described according to the standard factory settings. You can customize or disable the settings in the following menu:

To recreate the standard factory settings, choose **STD**.

To abort dosing procedure at any time, tap the cancel key **C**.

The instrument then returns to the home screen.

Note

The **Dosing steps** of instruments equipped with accessories may slightly differ from the example below.

- Powder dosing head is installed.
- Weighing pan is empty.
- ErgoClip is installed.

1 Tap **Start** > **Solid dosing**.

2 Enter **User ID** and confirm with **OK**.

3  **Note**

The **Sample ID** is not mandatory and the instrument does not check whether or not it is unique.

Enter **Sample ID** and confirm with **OK**.

4 Enter the amount **Target quantity** [mg] required and confirm with **OK**.

5 Enter the **Tolerance** in percent and confirm with **OK**.

6 Place sample vessel on weighing pan or ErgoClip and confirm with **OK**.

⇒ The value at the bottom of the display shows the weight of the sample vessel.

7  **Note**

If **SafePos** is selected, there is no request to lower the dosing head. It will be lowered automatically as soon as dosing starts.

Lower the position with the head height adjustment handle until dosing head is about 0.5 mm to 1 mm above the sample vessel and confirm with **OK**.

8  **Note**

To abort dosing during process, tap **C**.

Check if all necessary adjustments are completed:

To abort procedure, tap **No**.

To start dosing, tap **Yes**.

⇒ Instrument doses powder.

⇒ The results are being displayed.

9 To finish dosing process, confirm with **OK**.

4.2 Liquid dosing

4.2.1 Basic operation settings





Refer to your XPE Operating Instructions for further information on settings and parameters.

► www.mt.com/library

Navigation:  > **Liquid module** > **Mounted**

If you dose liquid for the first time, or after a master reset, check following settings:

Configure your settings in the following menu:

- Dosing must be chosen as application:  > **Dosing**
- Liquid module must be defined as mounted:  > **Liquid module** > **Mounted**
- RS232 device must be activated:  > **System** > **Peripherals** > **RFID / Quantos** > **RS232 built-in**

4.2.2 Dosing liquid

Navigation:  > **Dosing steps** > **Dosing steps (liquid)**

The following procedure is described according to the standard factory settings. You can customize or disable the settings in the following menu:

To recreate the standard factory settings, choose **STD**.

Note

To abort dosing procedure at any time, tap the cancel key **C**.
The instrument then returns to the home screen.

- Liquid dosing head is installed.
- Weighing pan is empty.
- If required, ErgoClip is installed.

- 1 Tap **Start** > **Liquid dosing**.
- 2 Enter **User ID** and confirm with **OK**.

3 **Note**

The **Sample ID** is not mandatory and the instrument does not check whether or not it is unique.
Enter **Sample ID** and confirm with **OK**.

- 4 Enter the amount **Target liquid [g]** required and confirm with **OK**.
- 5 Place sample vessel on weighing pan or ErgoClip and confirm with **OK**.
- 6 Lower position of dosing head until it is about 1 cm to 2 cm above the sample vessel and confirm with **OK**.

7 **Note**

To abort dosing during process, tap **C**.
Check if all necessary adjustments are completed:

To abort procedure, tap **No**.

To start dosing, tap **Yes**.

- ⇒ Pressure builds up.
- ⇒ Instrument doses liquid.
- ⇒ The results are being displayed.

- 8 To finish dosing process, confirm with **OK**.

Note

- Bubbles in the tube do not impair the result, because the target result is weighed.
- If you dose liquids that might crystalize, clean the dosing head from time to time.

4.2.3 Prepare a solution

Solution dosing works with a concentration **not** measured by volume [ml], but by weight [mg].

Concentration To calculate the concentration (C):

$$C = \text{mass of solid} / (\text{mass of solid} + \text{mass of liquid})$$

4.2.3.1 Dosing powder manually

Navigation:  > **Dosing steps** > **Dosing steps (solution)** > **STD**

If you have few solid samples you can leave the liquid dosing head installed.

The following procedure is described according to the standard factory settings:

- Liquid dosing head is installed.
 - Weighing pan is empty.
- 1 Tap **Start** > **Solution** > **Start manual dosing**.
 - 2 Enter **Substance** and confirm with **OK**.
 - 3 Enter **Lot ID** of substance and confirm with **OK**.
 - 4 Enter **User ID** and confirm with **OK**.

- 5 Enter **Sample ID** and confirm with **OK**.
- 6 Enter **Concentration [mg/g]** and confirm with **OK**.
- 7 Enter **Target solution [g]** and confirm with **OK**.
- 8 Place sample vessel on weighing pan and confirm with **OK**.
- 9 Dose manually the needed powder and confirm with **OK**.
 - ⇒ Dosing results are displayed.
- 10 Confirm results with **OK**.
- 11 To start liquid dosing tap **OK**.
 - ⇒ Instrument doses liquid.
- 12 Cap vessel and confirm with **OK**.
 - ⇒ Dosing results are displayed.
- 13 Confirm results with **OK**.

4.2.3.2 Dosing solution with pre-prepared solid

Navigation:  > **Dosing steps** > **Dosing steps (solution)** > **STD**

If you have sample vessels with already prepared solid, e.g., a tablet, you can leave the liquid dosing head installed.

The following procedure is described according to the standard factory settings:

- Liquid dosing head is installed.
 - Mass of solid is known.
 - Weighing pan is empty.
- 1 Tap **Start** > **Solution** > **Enter predosed quantity**.
 - 2 Enter the weight of the pre-dosed solid in **Enter predosed quantity** and confirm with **OK**.
 - 3 Enter **Concentration [mg/g]** and confirm with **OK**.
 - 4 Enter **Substance** and confirm with **OK**.
 - 5 Enter **Lot ID** of substance and confirm with **OK**.
 - 6 Enter **User ID** and confirm with **OK**.
 - 7 Enter **Sample ID** and confirm with **OK**.
 - 8 Place sample vessel on weighing pan and confirm with **OK**.
 - 9  **Note**
 To abort dosing during process, tap **C**
 Check, if all necessary adjustments are completed:
 To abort procedure, tap **No**.
 To start dosing, tap **Yes**.
 - ⇒ Pressure builds up.
 - ⇒ Instrument doses liquid.
 - 10 Cap sample vessel and confirm with **OK**.
 - ⇒ The results are being displayed.
 - 11 To finish dosing process, confirm with **OK**.

4.2.3.3 Automated powder dosing

Navigation:  > **Dosing steps** > **Dosing steps (solution)** > **STD**

The following procedure is described according to the standard factory settings:

- Powder dosing head is installed.
 - Weighing pan is empty.
- 1 Tap **Start** > **Solution**.
 - 2 Enter **User ID** and confirm with **OK**.
 - 3 Enter **Sample ID** and confirm with **OK**.

- 4 Enter **Concentration [mg/g]** and confirm with **OK**.
- 5 Enter **Target solution [g]** and confirm with **OK**.
- 6 Place sample vessel on weighing pan and confirm with **OK**.
 - ⇒ Instrument doses powder.
- 7 Insert liquid dosing head.
 - ⇒ Instrument reads head.
 - ⇒ Instrument doses liquid.
- 8 Cap vessel and confirm with **OK**.
 - ⇒ Dosing results are displayed.
- 9 Confirm results with **OK**.

4.2.4 Releasing pressure

If you need to release the pressure in e.g. the bottle, switch off the instrument.

Switching Off

- Press  until **Off** appears in the display.

Note

Do not disconnect the instrument from the power supply except if you will not be using the instrument for an extended period.

4.2.5 Handling the bottle



CAUTION

Injury due to splashing liquids

If the pressure in the bottle is not released, liquid might splash when removing the micro dosing valve, opening the bottle, or removing the liquid tube.

- Always release pressure by switching off the instrument before removing the micro dosing valve, opening the bottle, or removing the liquid tube.

Filling the bottle

The suction filter (1) has to be covered with liquid at all times. Before the suction filter gets dry, refill the bottle.

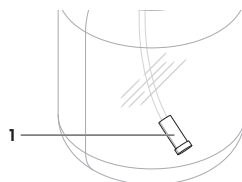

- Pressure is released.
- 1 Unscrew cap.
 - 2 Fill in the liquid. (max. is shown on bottle, e.g., 1000 ml).

Note

Do not exceed the maximum. The air above the liquid is necessary for dosing.

- 3 Screw cap on.
- 4 Check that the cap is tight.

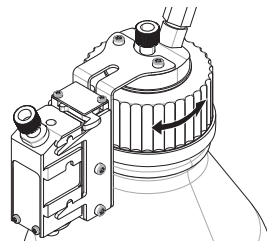

Changing the liquid of the bottle

You have only one cap with dosing head and want to change the liquid:

- Pressure is released.
- 1 Unplug air tube.

- 2 Unscrew cap.
- 3 Remove the suction filter.
- 4 If the cap needs to be cleaned, remove the air tube.
Unscrew the fastening nuts from the cap and the dosing head.
Rinse the cap with the appropriate solvent or liquid.
Insert both ends of the liquid tube at the dosing head and the cap, respectively.
- 5 If the liquid tube needs to be cleaned with a solvent, fill the bottle with the appropriate solvent.
Screw the cap on the bottle.
Insert the air tube on the cap.
Purge using the **Purge** function.
Unscrew the cap.
Dispose of the remainder of the solvent.
- 6 Attach a new suction filter.
- 7 Screw the cap on bottle with new liquid.
- 8 Check that the cap is tight.
- 9 Connect air tube to new bottle.
- 10 Purge using the **Purge** function.

Changing a bottle

If you have more than one bottle equipped with cap and dosing head:

- Pressure is released.
- 1 Install dosing head on dosing head support at the bottle.
 - 2 Unplug air tube by pressing ring (1) down and pulling tube (2) out carefully at the same time.
 - 3 To seal the bottle, insert pin into air tube fitting.
 - 4 Take the new bottle.
 - 5 Connect air tube to new bottle.
 - 6 To continue dosing with the new bottle, install dosing head.

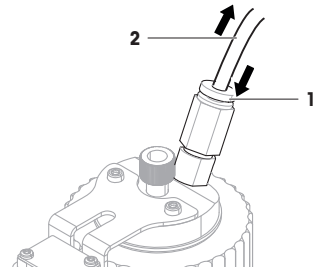

5 Technical Data

5.1 General data

Power supply

AC/DC adapter:

Primary: 100 – 240 V, -15%/+10%, 50/60 Hz

Secondary: 12 V DC $\pm 3\%$, 2.5 A (with electronic overload protection)

Cable for AC/DC adapter:

3-core, with country-specific plug

Power consumption (balance, powder dosing module, and autosampler):

12 V DC, 2.25 A

Polarity:

 with a current limited SELV (Safety Extra Low Voltage) output

Protection and standards

Overvoltage category:

II

Degree of pollution:

2

Protection:

Protected against dust and water

Standards for safety and EMC:

See Declaration of Conformity

Range of application:

For use in closed interior rooms only

Environmental conditions

Height above mean sea level:

Up to 4000 m

Ambient temperature:

5–40 °C

Relative air humidity:

Max. 80% up to 31 °C, linearly decreasing to 50% at 40 °C, noncondensing

Materials

Housing:

Die-cast aluminum, plastic, chrome steel and glass

6 Information on Standards

FCC Rules

This device complies with Industry Canada licence-exempt RSS standard(s) and part 15 of the FCC Rules. Operation is subject to the following two conditions: (1) this device may not cause interference, and (2) this device must accept any interference, including interference that may cause undesired operation of the device.

Changes or modifications not expressly approved by the party responsible for compliance could void the user's authority to operate the equipment.

This equipment has been tested and found to comply with the limits for a Class A digital device, pursuant to part 15 of the FCC Rules. These limits are designed to provide reasonable protection against harmful interference when the equipment is operated in a commercial environment. This equipment generates, uses, and can radiate radio frequency energy and, if not installed and used in accordance with the instruction manual, may cause harmful interference to radio communications. Operation of this equipment in a residential area is likely to cause harmful interference in which case the user will be required to correct the interference at his own expense.

GWP®

Good Weighing Practice™

GWP® is the global weighing standard, ensuring consistent accuracy of weighing processes, applicable to all equipment from any manufacturer. It helps to:

- Choose the appropriate balance or scale
- Calibrate and operate your weighing equipment with security
- Comply with quality and compliance standards in laboratory and manufacturing

 www.mt.com/GWP

For more information

Mettler-Toledo GmbH

Im Langacher 44
8606 Greifensee, Switzerland
www.mt.com/contact

Subject to technical changes.
© Mettler-Toledo GmbH 12/2018
30260314D en



30260314